

General Dimensions

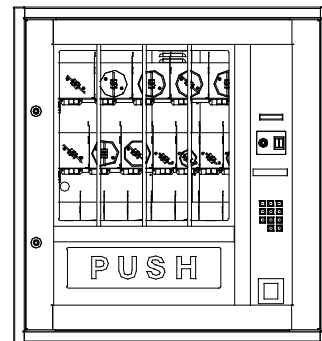

Rough Opening

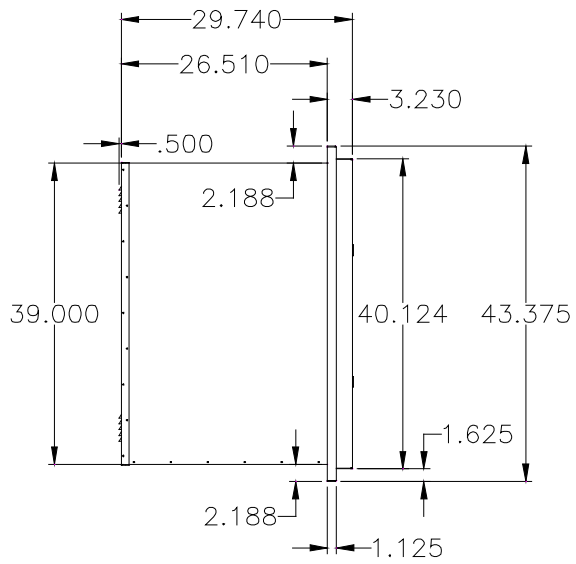
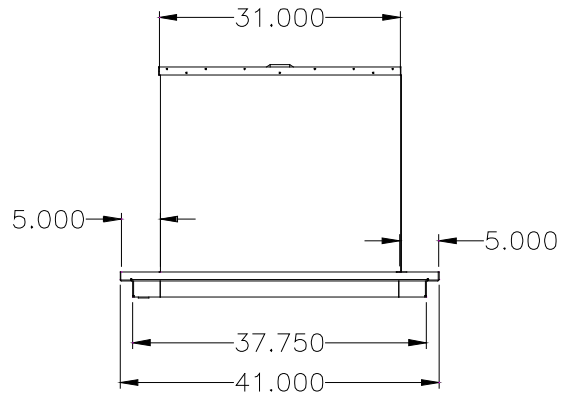
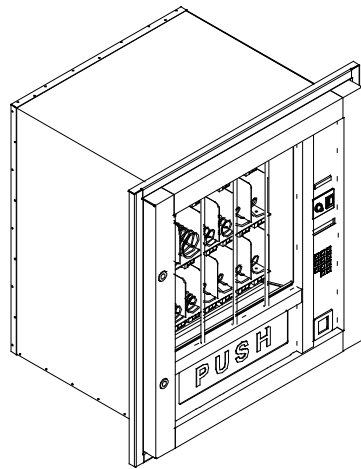
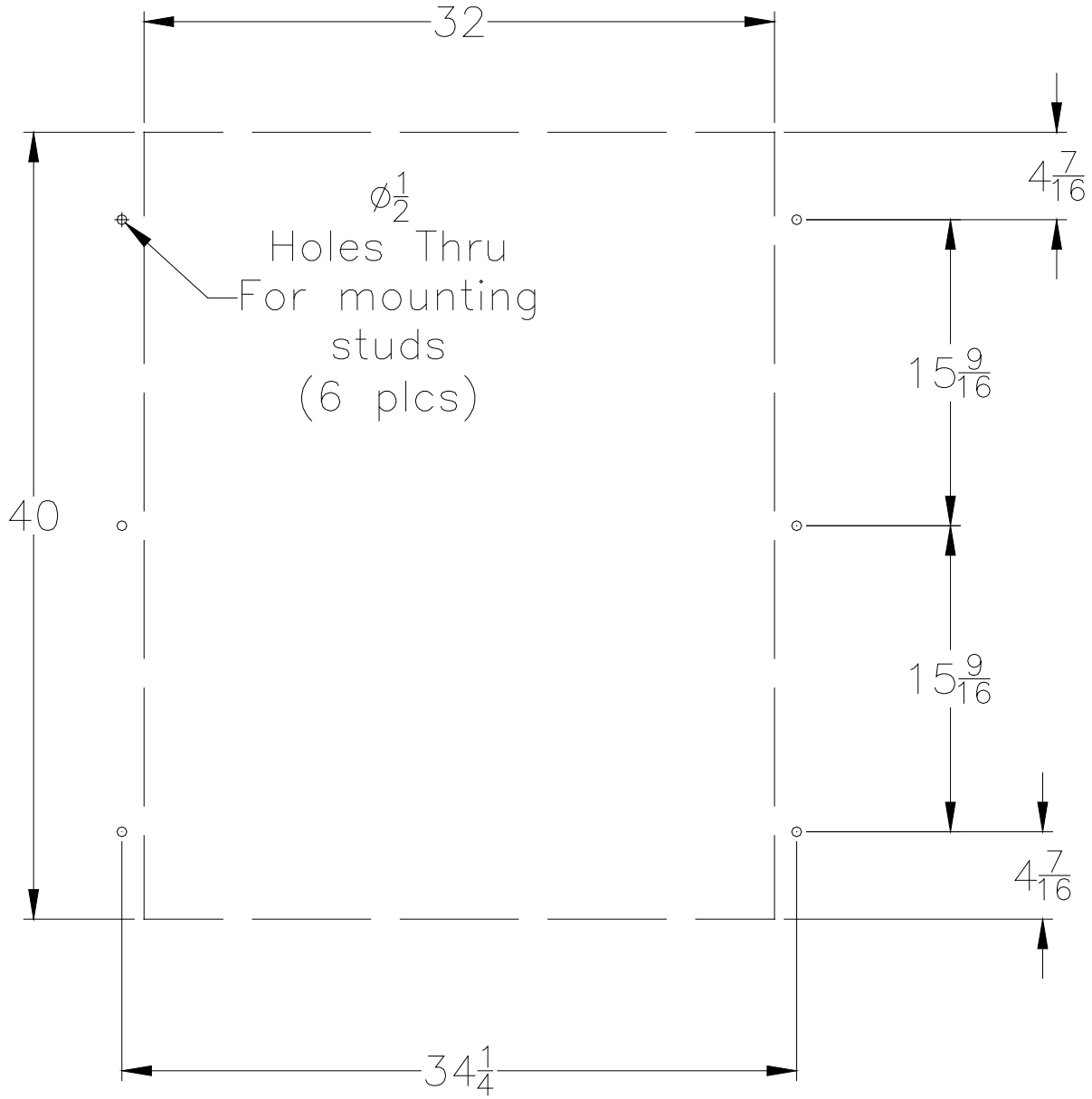

Installing the Vend-It!

CAUTION – *The Vend-It! is front weighted and very heavy.*

1. Screw 3/8-16 threaded rod into the 6 threaded holes in the back of the front flange until the rod bottoms out. The threaded rod should measure 1-1/2" longer than the wall is thick.
2. Press the included putty tape to the back of the front flange where shown. It may be necessary to use a small amount of caulk to hold the putty tape in place temporarily.

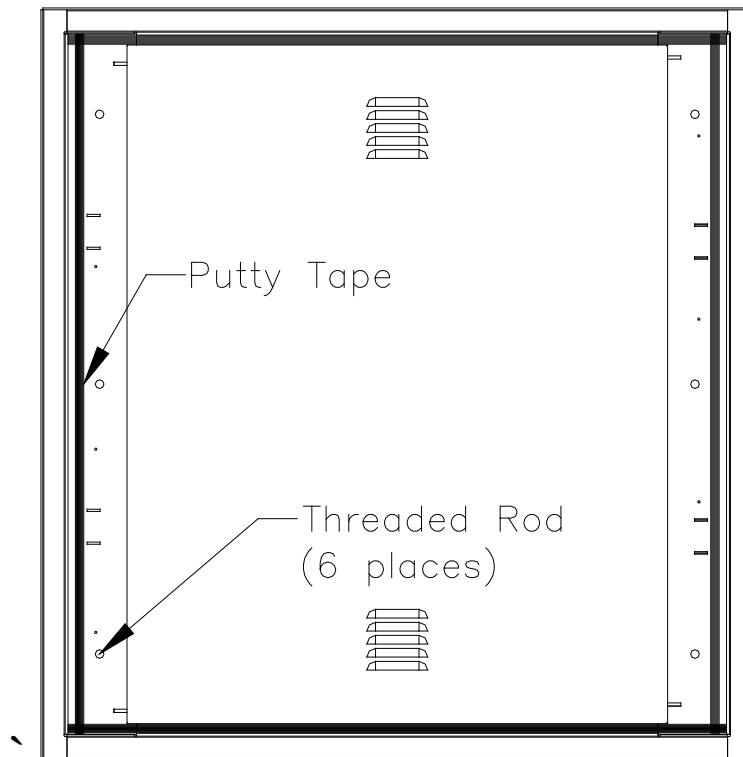

3. Slide the vendor into the wall guiding the threaded rods into the 1/2" diameter holes.
4. From inside the equipment room, place the retainer channels over the threaded rods where they extend through the wall. Place a washer and hex nut on each threaded rod and snug up securely.







Do Not Over Tighten the nuts! *Doing so may cause interference with the front door operation.*

5. Caulk the outside perimeter of the Vend-It! where the front flange meets the wall.
6. Plug the Vend-It! into a grounded outlet. Avoid the use of extension cords.

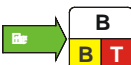
Initial Start-Up

1. Power On
2. Pull the Controls and Revenue Chassis out and Pivot it to access the VMC circuit board and programming keypad.
3. **Confirm “Motor Count” and “Configuration”**
 - a. Press the RED mode selector button on the VMC circuit board and enter the “Programming Mode”. The display will read “DIAGNOSE”.

NOTE – While you are in the “Programming Mode”, if there is more than 25 seconds between buttons, the VMC will automatically return to the “Sales Mode” as a machine protection function.

- b. Press the  key once. The display will read “MOTOR”.
- c. Press the  key once. The display will read “COUNT”.
- d. Press the  key once. The display should show the number of product columns (20). If not, refer to the troubleshooting guide in your operator’s manual.
- e. Press the  key once then the  key once. The display will read “MOTOR”.
- f. Press the  key once and the  two times. The display will read “CONFIG”.
- g. When the display reads “CONFIGURED” press the  key once.
- h. Press the RED mode selector button on the VMC circuit board. The display will return to the “Welcome Message”.













4. **Set the vend pricing.**

Before programming the vend prices, set the price display on the product shelves first. This will provide an easy to follow indicator of your pricing plan.

- a. Press the RED mode selector button on the VMC circuit board and enter the “Programming Mode”. The display will read “DIAGNOSE”.

NOTE – While you are in the “Programming Mode”, if there is more than 25 seconds between buttons, the VMC will automatically return to the “Sales Mode” as a machine protection function.

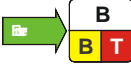
NOTE – If you return to the “Sales Mode” without pressing the  key, that data will not be retained.

- b. Press the  key once. The display will read “MENU 2”.
- c. Press the  key once and the  two times. The display will read “PRICE”.
- d. Press the  key two times. The display will read “SELECT - -“
- e. Enter the first selection you want to price, such as:  and then  for product “A1”
- f. Press the  key. The display will show the currently programmed price.
- g. Press the dollars and cents for the new price you want to assign, such as:
 ,  , and  for “\$2.00 “.
- h. Press the  key once. The display will again read “SELECT - -“.
- i. Repeat “e” through “f” for each product to be priced.
- j. When the last product has been priced, press the  three times, and press the RED mode selector button on the VMC circuit board. The display will return to the “Welcome Message”.

Your IVS *Vend-It* is now ready.